

Barrel Mount Davit Base- 1/2" to 3-1/2" thick

Designed for bolt on installation to existing edges, walls and other properly rated structures.

Specs

- Weight Capacity- 130-310 lbs. ANSI
- Capacity- 1 entrant only, 310 lb. max
- Item weight- 136.75 lbs.
- Hardware Material- Powder coated aluminum, plated alloy steel
- Lifeline- Galvanized steel wire rope
- Standards- OSHA 1926.502
ANSI 1910.66

Components

- PD1-** Davit Mast Assembly
- PD9-** Barrel Mount Davit Base
- PD3-** R50G Mounting Bracket
- PD4-** MW50G Mounting Bracket
- R50G-** Rescue SRL
- MW50G-** Work Winch

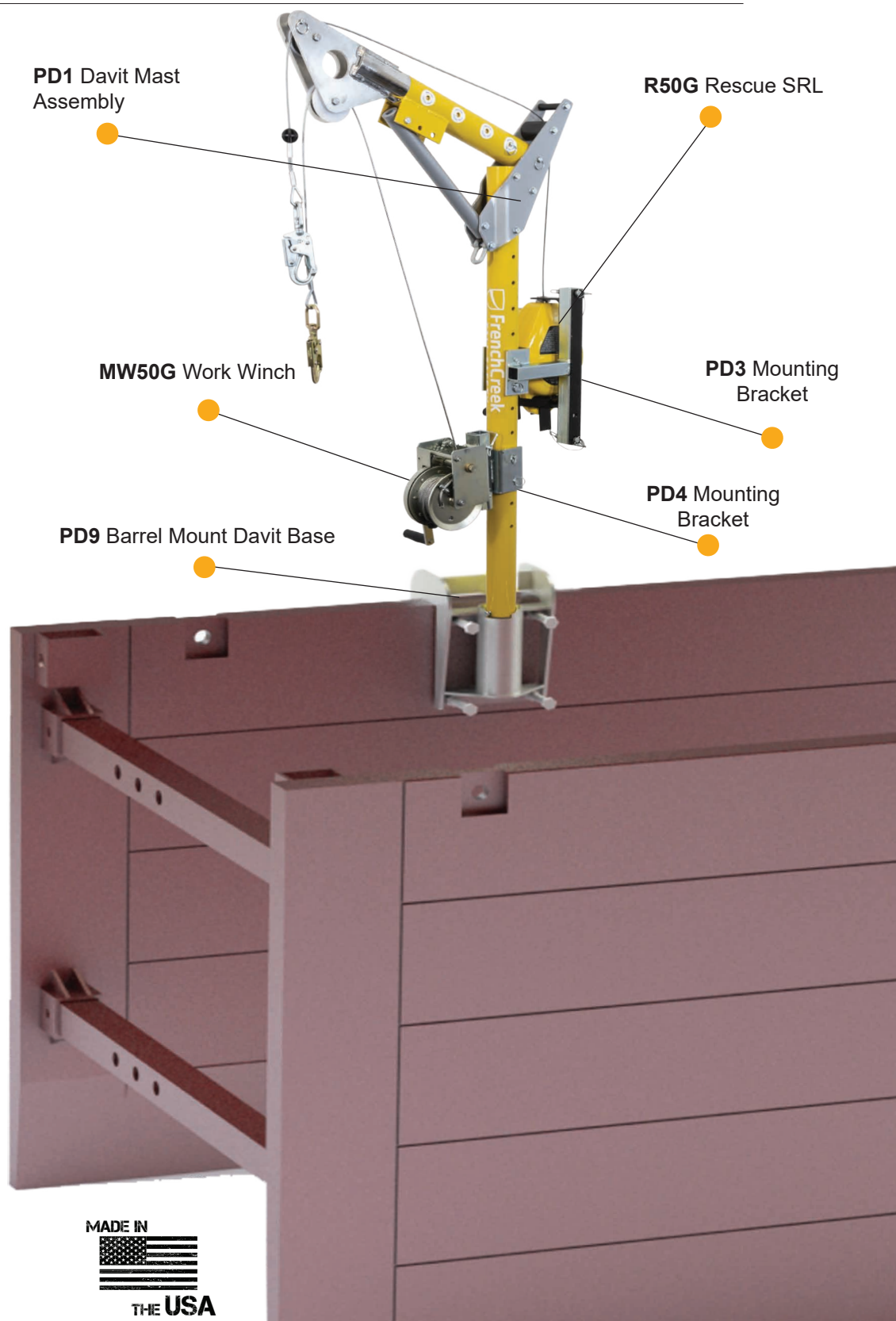

Ordering Information

PD1 Davit Mast Assembly
12"-30" offset reach



PD1
Davit mast assembly with telescoping adjustability from 12"-30". Includes attachment points for mechanical units. Used in conjunction with FrenchCreek Portable Davit system bases. Item weight 32.75 lbs.

PD9 Barrel Mount Davit Base
Attaches to properly rated structures 1/2" to 3-1/2" thick.



PD9
Attaches to properly rated structures 1/2" to 3-1/2" thick. 4pcs. 3/4" x 5" hex head set screws for securing to structure. Zinc plated welded steel construction with PVC mast sleeve insert. 180° mast rotation. 9" tall sleeve PVC insert. Item weight 32 lbs.

PD3 Mounting Bracket
Attaches R50G Rescue SRL



PD3
Used to attach R50G Rescue SRL to PD1 Davit Mast Assembly. Attaches with locking pins. Material: plated alloy steel. Item weight: 7.2 lbs.

PD4 Mounting Bracket
Attaches MW50G Work Winch



PD4
Used to attach MW50G Work Winch to PD1 Davit Mast Assembly. Attaches with locking pins. Material: plated alloy steel. Item weight: 4.8 lbs.

R50G Rescue SRL
ANSI Class SRL-R
3-way unit, 50' length



R50G
50' rescue SRL with raising/lowering capability. Mounts to PD1 Davit Mast Assembly using PD3 Mounting Bracket. Includes dual inertia braking system, pulleys & carabiner, load indicating snaphook. Three lifeline options: galvanized steel, stainless steel, technora rope. Aluminum cast housing. Item weight: 35 lbs.

MW50G Work Winch
50' length



MW50G
Offers raising and lowering capabilities with a friction brake that prevents the unit from free-wheeling when under a load. Mounts to PD1 Davit Mast Assembly using PD4 Mounting Bracket. Includes pulleys, carabiner and swivel snaphook. Three lifeline options: galvanized steel, stainless steel, technora rope. Aluminum cast housing. Item weight: 25 lbs.